

Allowable Loads lbs (kN)<sup>A,C</sup>

Chord	Clip on one face <sup>B</sup>					
	#10SDS into bottom chord			#12SDS into bottom chord		
	U	P1	P2	U	P1	P2
28TSC2.75	400 (1.78)	1030 (4.58)	520 (2.31)	400 (1.78)	1100 (4.89)	570 (2.54)
33TSC2.75		1280 (5.69)	570 (2.54)		1360 (6.05)	
43TSC2.75		1820 (8.10)			1820 (8.10)	
28TSC3.00 or 28TSC4.00	740 (3.29)	1030 (4.58)	520 (2.31)	740 (3.29)	1100 (4.89)	
33TSC3.00 or 33TSC4.00		1280 (5.69)	570 (2.54)		1360 (6.05)	
43 & 54TSC3.00, 43, 54, 68 & 97TSC4.00		1820 (8.10)			1820 (8.10)	
Chord	Clip on both faces					
	#10SDS into bottom chord			#12SDS into bottom chord		
	U	P1	P2	U	P1	P2
28TSC	1940 (8.63)	2050 (9.12)	1050 (4.67)	1940 (8.63)	2190 (9.74)	1190 (5.29)
33TSC		2550 (11.34)	1210 (5.38)		2720 (12.10)	1380 (6.14)
43, 54, 68 & 97TSC		3640 (16.19)	1470 (6.54)		3640 (16.19)	1470 (6.54)

- A. Allowable loads shown are not in combination.  
 B. Uplift connections with clip on one face require a web above connection.  
 C. Chart values apply to steel thickness between 3/16" (4.76mm) and 1/2" (12.70mm), when connecting to steel greater than 1/2" (12.70mm) thick refer to TS040C.

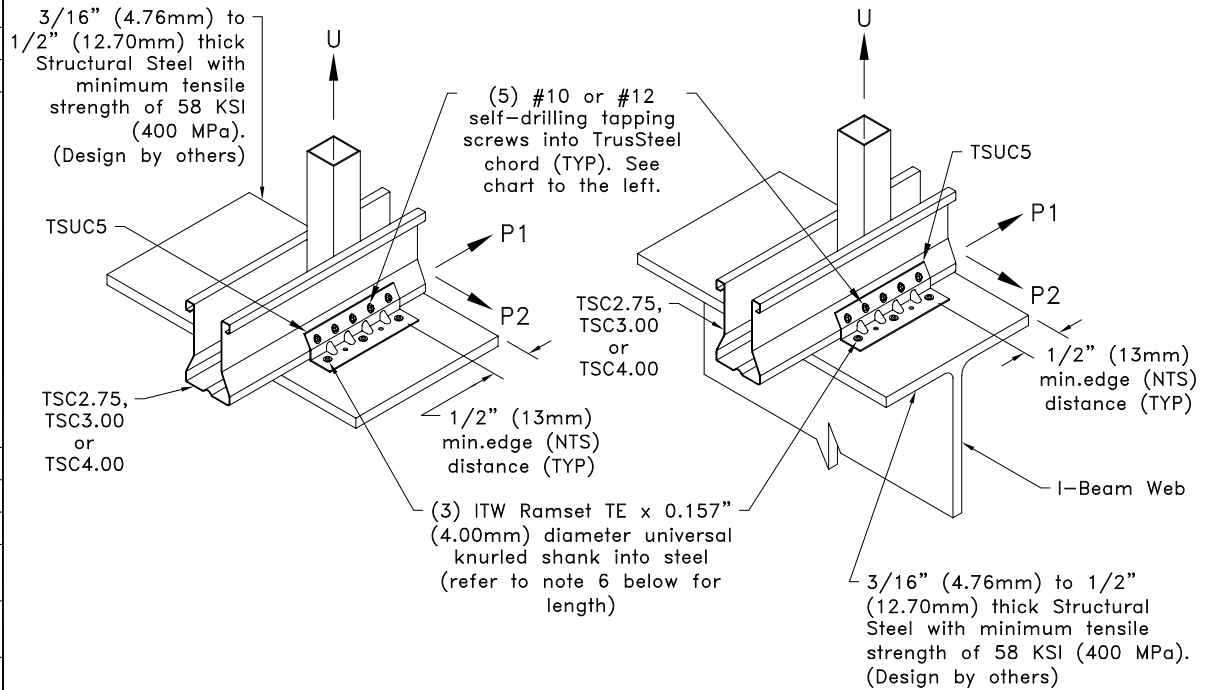
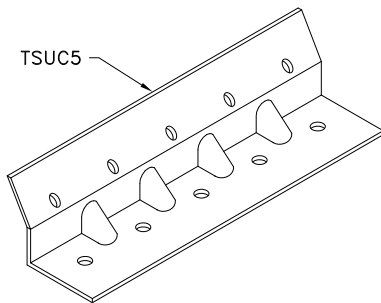

**General Notes:**

1. If a clip is required on both faces, attach the second clip to the opposite face of the chord as detailed.
2. Multi-ply trusses require a clip on each face. Refer to TrusSteel detail drawing TS023A for ply-to-ply connections for 3-Ply trusses with a clip on each face.
3. Install pins in the two outside holes and the middle of TSUC5 clip.
4. Pins must be driven through existing holes in TSUC5 clip and be driven perpendicular to steel surface.
5. Care must be taken to ensure pins are not overdriven. Pins that are overdriven may puncture surface of TSUC5 clip causing damage. If TSUC5 clip is damaged, the values given on this detail are no longer valid.
6. Pin length must be long enough to ensure the tip either penetrates completely through the steel, or shows evidence of the steel deformation that occurs just before penetration.
7. Do not install pins into area of beam flange directly above beam web.
8. Allowable ITW Ramset TE Fastener values into steel bearing are per ICC ESR-1799 (June 2017). Refer to ESR regarding proper installation of fastener.
9. Cold-Formed Steel Calculations are per the AISI 2016 "North American Specifications for the Design of Cold-Formed Steel Structural Members" (S100-16).



www.TrusSteel.com

Florida: 6750 Forum Drive, Suite 305 / Orlando, FL 32821 / (800) 755-6001  
 Missouri: 13723 Riverport Drive, Suite 200 / Maryland Heights, MO 63043 / (800) 326-4102

**TSUC5 Uplift Attachment To  
 Structural Steel Bearing Using ITW  
 Ramset Pins  
 (Steel From 3/16" to 1/2" Thick)**

Alpine, a division of ITW Building Components Group, Inc. shall not be responsible for any performance failure in a connection due to a deviation from this detail. Any variation from this detail shall be approved in advance by Alpine, a division of ITW Building Components Group, Inc.

**Standard Detail:**  
 TS040B

**Date:**  
 10/11/18

**TrusSteel Detail Category:**  
 Truss-To-Bearing: Structural Steel