

BXUV.P525 -

Design/System/Construction/Assembly Usage Disclaimer

- Authorities Having Jurisdiction should be consulted in all cases as to the particular requirements covering the installation and use of UL Certified products, equipment, system, devices, and materials.
- Authorities Having Jurisdiction should be consulted before construction.
- Fire resistance assemblies and products are developed by the design submitter and have been investigated by UL for compliance with applicable requirements. The published information cannot always address every construction nuance encountered in the field.
- When field issues arise, it is recommended the first contact for assistance be the technical service staff provided by the product manufacturer noted for the design. Users of fire resistance assemblies are advised to consult the general Guide Information for each product category and each group of assemblies. The Guide Information includes specifics concerning alternate materials and alternate methods of construction.
- Only products which bear UL's Mark are considered Certified.

BXUV - Fire Resistance Ratings - ANSI/UL 263 Certified for United States

BXUV7 - Fire Resistance Ratings - CAN/ULC-S101 Certified for Canada

See General Information for Fire-resistance Ratings - ANSI/UL 263 Certified for United States Design Criteria and Allowable Variances

See General Information for Fire Resistance Ratings - CAN/ULC-S101 Certified for Canada Design Criteria and Allowable Variances

Design No. P525

November 14, 2019

Restrained Assembly Rating - 1, 1-1/2 and 2 Hr (See Items 3A, 4B, 4C, 5, 5A, 5B and 8)

Unrestrained Assembly Rating - 1, 1-1/2 and 2 Hr (See Items 3A, 4B, 4C, 5, 5A, 5B and 8)

This design was evaluated using a load design method other than the Limit States Design Method (e.g., Working Stress Design Method). For jurisdictions employing the Limit States Design Method, such as Canada, a load restriction factor shall be used — See Guide BXUV or BXUV7

*** Indicates such products shall bear the UL or cUL Certification Mark for jurisdictions employing the UL or cUL Certification (such as Canada), respectively.**

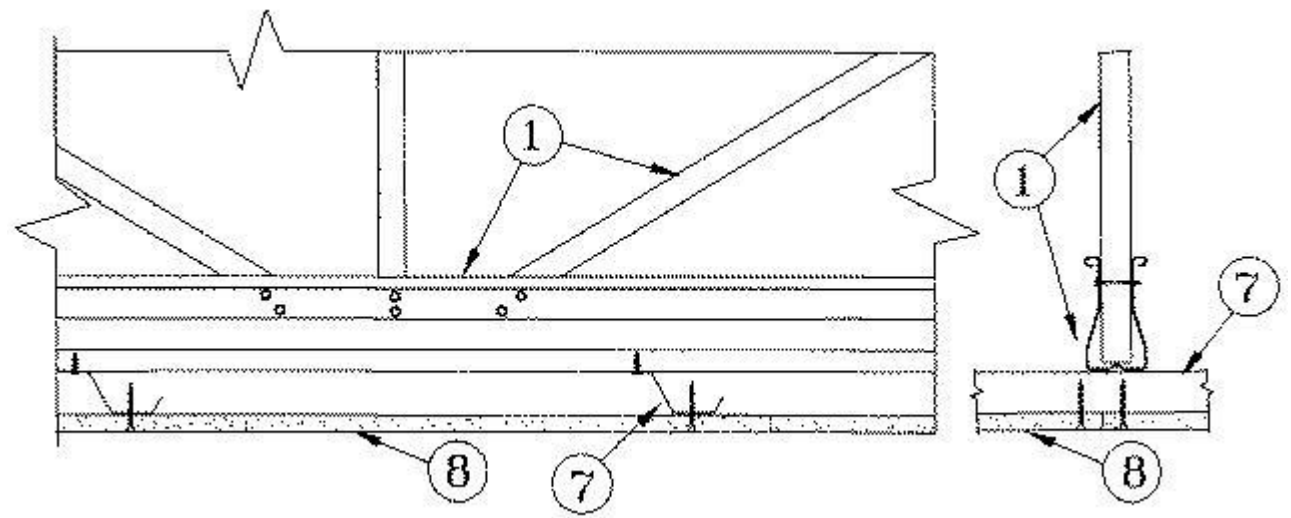
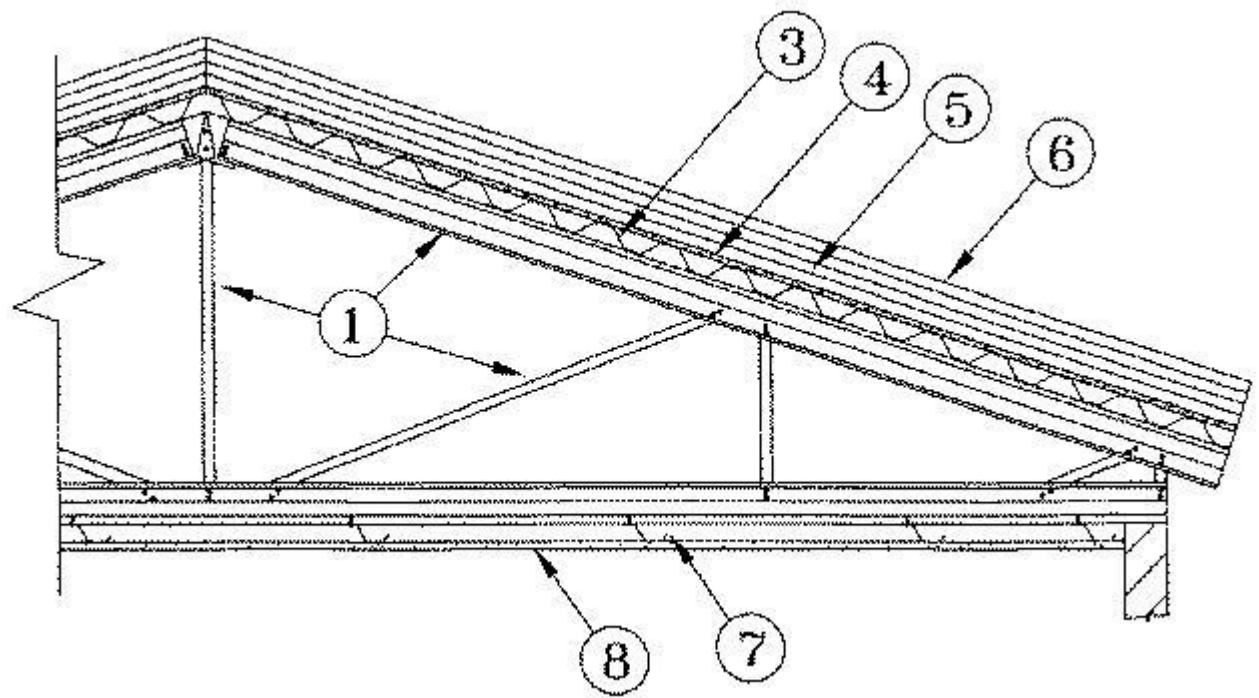

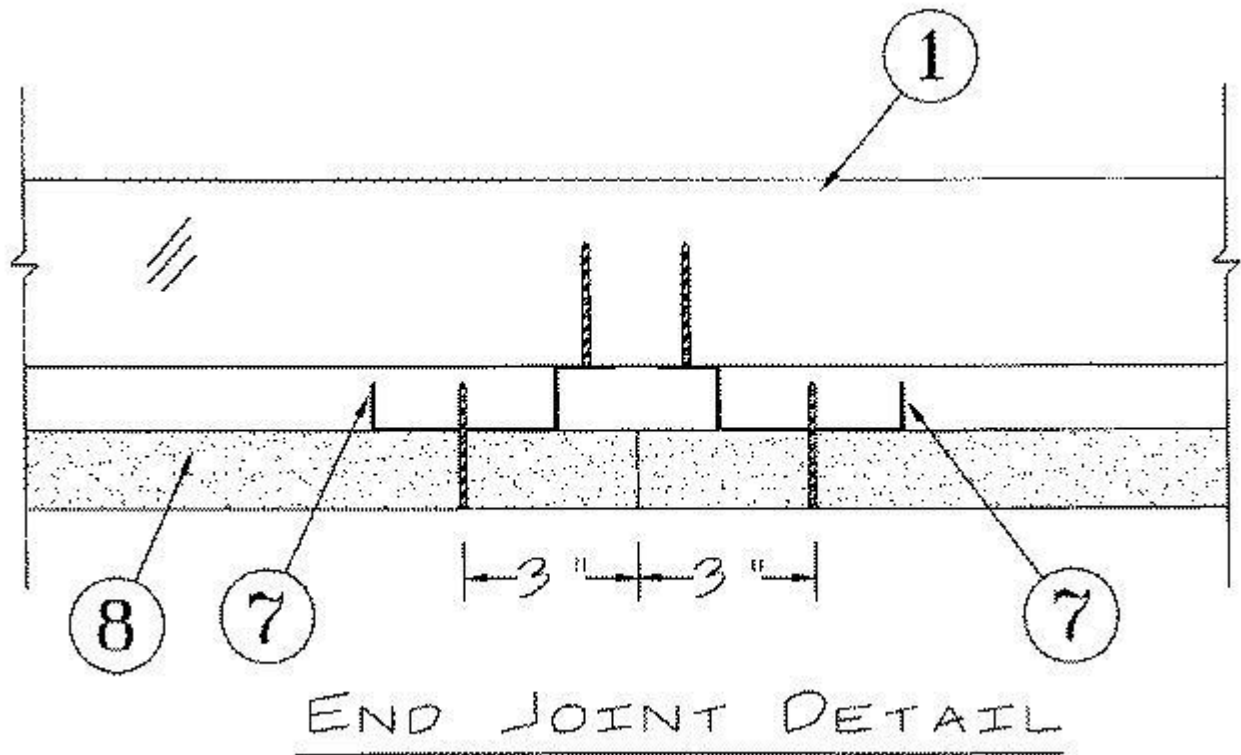

1. Structural Steel Members* — Pre-fabricated light gauge steel truss system consisting of cold-formed, galv steel chord and web sections. Trusses fabricated in various sizes, depths and from various steel thickness. Trusses spaced a max of 48 in. OC.
TRUSSTEEL, DIV OF ITW BUILDING COMPONENTS INC — TrusSteel

2. Bridging — (Not Shown)—Location of lateral bracing for truss chord and web sections to be specified on truss engineering.

3. Steel Floor and Form Units — (Classified or Unclassified)—Corrugated or fluted steel form units, min 22 MSG painted or galv steel, welded or mechanically fastened at a max 12 in. OC to the top chords.

3A. Steel Floor and Form Units — (Classified or Unclassified) — As an alternate to Item 3 - Corrugated or fluted steel form units, min 26 MSG, painted or galv units welded or mechanically fastened max 12 in. OC to the top chord of trusses. When used, max hourly rating is reduced to 1 hr.

4. Cementitious Backer Units* — Nom 1/2 or 5/8 in. thick sheets. End-joints to occur over crests of steel roof deck with end-joints staggered in adjacent rows. Units loosely laid, adhered or mechanically attached to steel roof deck.
UNITED STATES GYPSUM CO — Type DCB

4A. Gypsum Board — (Classified or Unclassified)—(Not Shown)—As an alternate to Item 4, gypsum sheathing, min 1/2 in. thick, applied perpendicular to steel roof deck. End joints to occur over crests of steel roof deck. Sheathing loosely laid, adhered or mechanically attached to steel roof deck. See Gypsum Board, (CKNX) category for names of Classified companies.

4B. Precast Concrete Units* — Not Shown - To be used in lieu of Items 3 and 4 - When used the maximum ratings are 1 Hour -10 ft. long, 15 in. wide, 2 in. deep with T & G sheet metal edges. End joints in adjacent rows shall be staggered not less than 30 in. Each cut end unit at walls must be supported at not less than two supports. Units attached to trusses with clips (Item 4D). Clips secured to units with two 4d coated nails. Clips located to provide for one clip per unit truss. As an alternate, units may be attached to each truss and walls with 1/2 in. long welds or screws 1 in. longer than the thickness of the unit.

MARTIN FIREPROOFING CORP

4C. **Building Units*** — Not Shown - To be used in lieu of Items 3 and 4 - When used the maximum ratings are 1 Hour -10 ft. long, 18 in. wide, 2 in. deep with T & G sheet metal edges. End joints in adjacent rows shall be staggered not less than 30 in. Each cut end unit at walls must be supported at not less than two supports. Units attached to trusses with clips (Item 4D). Clips secured to units with two 4d coated nails. Clips located to provide for one clip per unit truss. As an alternate, units may be attached to each truss and walls with 1/2 in. long welds or screws 1 in. longer than the thickness of the unit.

MIDCON PRODUCTS INC

4D. **Clips** — Not Shown - For use with Items 4B and 4C - Formed from 16 MSG galv steel, 1-9/16 in. wide by 1-1/4 in. high. Provided with two 1/8 in. diam holes near top and notched to fit top chord of joist.

5. **Roof Insulation—Foamed Plastic*** — Any polyisocyanurate foamed plastic insulation boards bearing the UL Classification Marking. No min thickness required for the 1 hr assembly ratings, 2 in. for the 1-1/2 hr assembly ratings, and 4 in. for the 2 hr rating, with no limit on max overall thickness. Boards installed over the cementitious backer units (Item 4) or gypsum sheathing (Item 4A) , with the end-joints staggered in adjacent rows. When applied in more than one layer, each layer of board to be offset in both directions from layer below in order to lap all joints. Boards loosely laid, adhered or mechanically fastened to cementitious backer units or gypsum sheathing, and to steel roof deck (Item 3). See Foamed Plastic (CCVW) category in the Fire Resistance Directory.

5A. **Roof Insulation—Foamed Plastic*** — (Not Shown)—As an alternate to Item 5—For 1 and 1-1/2 hr ratings only. Any polystyrene foamed plastic insulation boards bearing the UL Classification Marking. No min thickness required for the 1 hr assembly ratings and 2 in. for the 1-1/2 hr assembly ratings, with no limit on max overall thickness. Boards installed over the cementitious backer units (Item 4) or gypsum sheathing (Item 4A) , with the end-joints staggered in adjacent rows. When applied in more than one layer, each layer of board to be offset in both directions from layer below in order to lap all joints. Boards loosely laid, adhered or mechanically fastened to cementitious backer units or gypsum sheathing, and to steel roof deck (Item 3). See Foamed Plastic (BRYX) category in the Building Materials Directory or Foamed Plastic (CCVW) category in the Fire Resistance Directory.

5B. **Roof Insulation—Mineral and Fiber Boards*** — (Not Shown)—As an alternate to Item 5—Mineral wool, glass fiber or perlite insulation boards, 24 by 48 in. min size, applied in one or more layers. No min thickness required for the 1 hr assembly ratings, 2 in. for the 1-1/2 hr assembly ratings, and 4 in. for the 2 hr rating, with no limit on max overall thickness. Boards installed over the cementitious backer units (Item 4) or gypsum sheathing (Item 4A) , with the end-joints staggered in adjacent rows. When applied in more than one layer, each layer of board to be offset in both directions from layer below in order to lap all joints. Boards loosely laid, adhered or mechanically fastened to cementitious backer units or gypsum sheathing, and to steel roof deck (Item 3). See Mineral and Fiber Boards (BQXR) category in the Building Materials Directory or Mineral and Fiber Boards (CERZ) in the Fire Resistance Directory.

5C. **Roof Insulation-Building Units* (Not Shown)** — As an alternate to Item 5—Any polyisocyanurate foamed plastic insulation faced on the top surface with oriented strand board or faced on the underside or both sides with wood fiber board, bearing the UL Classification Marking for Fire Resistance. No min thickness of the polyisocyanurate foamed plastic core required for the 1 hr assembly ratings, min 2 in. polyisocyanurate foamed plastic core for the 1-1/2 hr assembly ratings and min 4 in. polyisocyanurate foamed plastic core for the 2 hr rating with no limit on max overall thickness. Boards installed over the cementitious backer units (Item 4) or gypsum sheathing (Item 4A), with the end-joints staggered in adjacent rows. When applied in more than one layer, each layer of board to be offset in both directions from layer below in order to lap all joints. Boards loosely laid, adhered or mechanically fastened to cementitious backer units or gypsum sheathing and to steel roof deck (Item 3). See Building Units (BZXX) category in the Fire Resistance Directory.

6. **Roof Covering*** — Consisting of hot-mopped or cold-application materials compatible with insulation(s) described herein which can provide Class A, B or C coverings. See Roofing Materials and Systems Directory, Roof Covering Materials (TGFU).

6A. **Roofing Membrane*** — (Not Shown)—In lieu of Item 6, single-ply membrane that is either ballasted, adhered or mechanically attached to the insulation(s) described herein as permitted under the respective company's Classification. See Fire Resistance Directory, Roofing Membranes (CHCI) category.

6B. **Metal Roof Deck Panels*** — In lieu of or in addition to Items 6 and 6A, the roof-covering may consist of mechanically fastened galv or painted steel roof deck panels. Panels may be installed above a steel purlin assembly per metal roof deck manufacturer's specifications. Steel purlin assembly to be installed transverse to steel roof trusses (Item 1). A line of sealant or

tape may be used at panel side and end laps. See Metal Roof Deck Panels category (TJPV) in the Roofing Materials and Systems Directory or Fire Resistance Directory (CETW) for names of manufacturers.

6C. Roof Covering* — In lieu of Item 6 - Any UL Class A, B or C Prepared Roof Covering (TFWZ) acceptable for use over plywood sheathing or nonveneer APA Rated Series Sheathing. Sheathing mechanically fastened through roof insulation to steel rock deck. As an alternate to the plywood sheathing or nonveneer APA Rated Series Sheathing, the Prepared Roof Covering (TFWZ) may be applied directly to the Building Units* (Item 5C) if the building units also carry the UL Classification Marking for Prepared Roofing Accessories (TGDY). Fasteners to be of sufficient length to penetrate top chord of truss by 3/8 in.

7. Furring Channels — Resilient channels formed of 25 MSG galv steel, installed perpendicular to the trusses (Item 1) when steel trusses are spaced a max 24 in. OC. Resilient channels spaced a max of 16 in. OC. Channels oriented opposite at wallboard butt-joints. Channel splices overlapped 4 in. beneath steel trusses. Channels secured to each truss with Type S12 by 1/2 in. long screws.

7A. Furring Channels — (Not Shown) — As an alternate to Item 7 — Hat channels min 20 MSG galv steel, min 2-5/8 in. wide by min 7/8 in. deep, installed perpendicular to the trusses (Item 1) spaced a max of 16 in. OC. Two courses of channel positioned 6 in. OC, 3 in. from each end of wallboard. Channel splices overlapped 6 in. beneath steel trusses. Channels secured to each truss with No. 18 SWG steel wire double strand saddle ties. Channels tied together with double strand of No. 18 SWG steel wire at each end overlap.

7B. Furring Channels — As an alternate to Items 7 and 7A, resilient channels, double legged formed of 25 MSG galv steel, 2-7/8 in. wide by 1/2 in. deep, installed perpendicular to the trusses (Item 1) spaced max 16 in. OC. Two courses of resilient channel positioned 6 in. OC at wallboard butt-joints (3 in. from each end of wallboard). Channel splices overlapped 4 in. beneath steel trusses. Channels secured to each truss with Type S12 by 1/2 in. long screws or with No. 18 SWG galv steel wire double strand saddle ties. Channels tied together with double strand of No. 18 SWG galv steel wire at each end of overlap .

8. Gypsum Board* — For all Ratings except the 2 Hr Unrestrained Assembly Rating—One layer of nom 5/8 in. thick by 48 in. wide boards, installed with long dimension parallel to trusses. Attached to the resilient channels using 1 in. long Type S bugle-head screws spaced 12 in. OC along butted end-joints and 12 in. OC in the field. For the 2 Hr Unrestrained Rating — Two layers of nom 5/8 in. thick by 48 in. wide boards, installed with long dimension parallel to trusses. Base layer attached as described above. Face layer attached to the resilient channels using 1-5/8 in. long Type S bugle-head screws spaced 12 in. OC along butted end-joints and 12 in. OC in the field. Screws staggered from base layer screws. Face layer side and end joints offset a minimum 16 in. from base layer side and end joints.

CGC INC — Types C, IP-X2, IPC-AR, ULIX. (When Type ULIX is used Screw spacig is adjusted to 8 in. OC for all layers)..

UNITED STATES GYPSUM CO — Types C, IP-X2, IPC-AR, ULIX. (When Type ULIX is used Screw spacig is adjusted to 8 in. OC for all layers).

USG BORAL DRYWALL SFZ LLC — Type C

USG MEXICO S A DE C V — Types C, IP-X2, IPC-AR.

9. Finishing System — (Not Shown)—Vinyl, dry or premixed joint compound, applied in two coats to joints and screw heads; paper tape, 2 in. wide, embedded in first layer if compound over all joints.

Alternate Ceiling Membrane — Not Shown —

10. Steel Framing Members —

- a. **Main Runners** — Installed perpendicular to Structural Steel Members — Nom 10 or 12 ft long, 15/16 in. or 1-1/2 in. wide face, spaced 4 ft OC. Main runners hung a min of 2 in. from bottom chord of Structural Steel Members with 12 SWG galv steel wire. Wires located a max of 48 in. OC.

b. **Cross tees or channels** — Nom 4 ft long, 15/16 in. or 1-1/2 in. wide face, or cross channels, nom 4 ft long, 1-1/2 in. wide face, installed perpendicular to the main runners, spaced 16 in. OC. Additional cross tees or channels used at 8 in. from each side of butted wallboard end joints. The cross tees or channels may be riveted or screw-attached to the wall angle or channel to facilitate the ceiling installation.

c. **Wall angles or channels** — Used to support steel framing member ends and for screw-attachment of the gypsum wallboard — Min 0.016 in. thick painted or galvanized steel angle with 1 in. legs or min. 0.016 in. thick painted or galvanized steel channel with a 1 by 1-1/2 by 1 in. profile, attached to walls at perimeter of ceiling with fasteners 16 in. OC.

CGC INC — Type DGL or RX

USG INTERIORS LLC — Type DGL or RX

10A. **Alternate Steel Framing Members*** — (Not Shown) - As an alternate to Item 10 - Main runners nom 12 ft long, spaced 72 in. OC. Main runners suspended by min 12 SWG galv steel hanger wires spaced 48 in. OC. Cross tees, nom 6 ft long, installed perpendicular to main runners and spaced 24 in. OC. Additional 6 ft long cross tees required at each gypsum board end joint with butted gypsum board end joints centered between cross tees spaced 8 in. OC. The main runners and cross tees may be riveted or screw attached to the wall angle or channel to facilitate the ceiling installation.

USG INTERIORS LLC — Type DGL or RX

11. **Gypsum Board*** — For use with Steel Framing Members (Item 10) - For the 1 and 1-1/2 hr ratings - One layer of nominal 5/8 in. thick by 48 in. wide boards, installed with long dimension parallel to the main runners. Wallboard fastened to each cross tee or channel with five wallboard screws, with one screw located at the mid-span of the cross tee or channel, one screw located 12 in. from and on each side of the cross tee or channel mid span, and one screw located 1-1/2 in. from each wallboard side joint. Except at wallboard end joints, wallboard screws shall be located on alternating sides of cross tee flange. At wallboard end joints, wallboard screws shall be located 1/2 in. from the joint. Wallboard fastened to main runners with wallboard screws 1/2 in. from side joints, midway between intersections with cross tees or channels (16 in. OC). End joints of adjacent wallboard sheets shall be staggered not less than 32 in. Wallboard sheets screw attached to leg of wall angle with wallboard screws spaced 12 in. OC. Joints treated as described in Item 9. For the 2 hr rating - Two layers of nominal 5/8 in. thick by 48 in. wide boards. Inner layer installed with long dimension perpendicular to cross tees with side joints centered along main runners and end joints centered along cross tees. Inner layer fastened to cross tees with 1-1/4 in. long Type S bugle-head steel screws spaced 8 in. OC along butted end joints and 12 in. OC in the field of the board. End joints of adjacent wallboard sheets shall be staggered not less than 4 ft OC. Outer layer attached to the cross tees through inner layer using 1-7/8 in. long Type S bugle-head steel screws spaced 8 in. OC at butted end joints and 12 in. OC in the field. Butted end joints to be centered along cross tees and be offset a min of 32 in. from end joints of inner layer. Rows of screws on both sides of butted end joints of each layer shall be located 3/8 to 1/2 in. from end joints. Butted side joints of outer layer to be offset a min of 18 in. from butted side joints of inner layer. Joints treated as described in Item 9.

CGC INC — Type C, IP-X2, IPC-AR, ULIX. (When Type ULIX is used Screw spacing is adjusted to 8 in. OC for all layers in all directions)

UNITED STATES GYPSUM CO — Type C, IP-X2, IPC-AR, ULIX. (When Type ULIX is used Screw spacing is adjusted to 8 in. OC for all layers in all directions)

USG BORAL DRYWALL SFZ LLC — Type C

USG MEXICO S A DE C V — Type C, IP-X2, IPC-AR

12. **Gypsum Board*** — For use with Steel Framing Members (Item 10A) - For the 1 and 1-1/2 hr ratings - One layer of nominal 5/8 in. thick by 48 in. wide boards, installed with long dimension (side joints) perpendicular to the 6 ft long cross tees with the end joints staggered min 4 ft and centered between cross tees which are spaced 8 in. OC. Gypsum board side joints may occur beneath or between main runners. Prior to installation of the gypsum board sheets, backer strips consisting of nom 7-3/4 in.

wide pieces of gypsum board are to be laid atop the cross tee flanges and centered over each butted end joint location. The backer strips are to be secured to the flanges of the cross tees at opposite corners of the backer strip with hold down clips to prevent the backer strips from being uplifted during screw-attachment of the gypsum board sheets. Gypsum board fastened to cross tees with 1 in. drywall screws spaced 1 in. and 4 in. from the side joints and max 8 in. OC in the field of the board. The butted end joints are to be secured to the backer strip with No. 10 by 1-1/2 in. long Type G laminating screws located 1 in. from each side of the butted end joint and spaced 1 in. and 4 in. from the side joints and max 8 in. OC in the field of the board.

CGC INC — Type C, IP-X2, IPC-AR, ULIX

UNITED STATES GYPSUM CO — Type C, IP-X2, IPC-AR, ULIX

USG BORAL DRYWALL SFZ LLC — Type C

USG MEXICO S A DE C V — Type C, IP-X2, IPC-AR

*** Indicates such products shall bear the UL or cUL Certification Mark for jurisdictions employing the UL or cUL Certification (such as Canada), respectively.**

Last Updated on 2019-11-14

The appearance of a company's name or product in this database does not in itself assure that products so identified have been manufactured under UL's Follow-Up Service. Only those products bearing the UL Mark should be considered to be Certified and covered under UL's Follow-Up Service. Always look for the Mark on the product.

UL permits the reproduction of the material contained in the Online Certification Directory subject to the following conditions: 1. The Guide Information, Assemblies, Constructions, Designs, Systems, and/or Certifications (files) must be presented in their entirety and in a non-misleading manner, without any manipulation of the data (or drawings). 2. The statement "Reprinted from the Online Certifications Directory with permission from UL" must appear adjacent to the extracted material. In addition, the reprinted material must include a copyright notice in the following format: "© 2020 UL LLC"