

Allowable Loads lbs (kN) ^A		
Chord	Clip on both faces	
	#10SDS into bottom chord	
	U	P1
28TSC3.00	1220 (5.43)	650 (2.89)
33TSC3.00	1220 (5.43)	790 (3.51)
43TSC3.00	1220 (5.43)	1130 (5.03)
54TSC3.00	1220 (5.43)	1330 (5.92)
28TSC4.00	1220 (5.43)	730 (3.25)
33TSC4.00	1220 (5.43)	890 (3.96)
43TSC4.00	1220 (5.43)	1250 (5.56)
54TSC4.00	1220 (5.43)	1480 (6.58)
68TSC4.00	1220 (5.43)	1640 (7.30)
97TSC4.00	1220 (5.43)	1740 (7.74)

A. Allowable loads shown are not in combination.

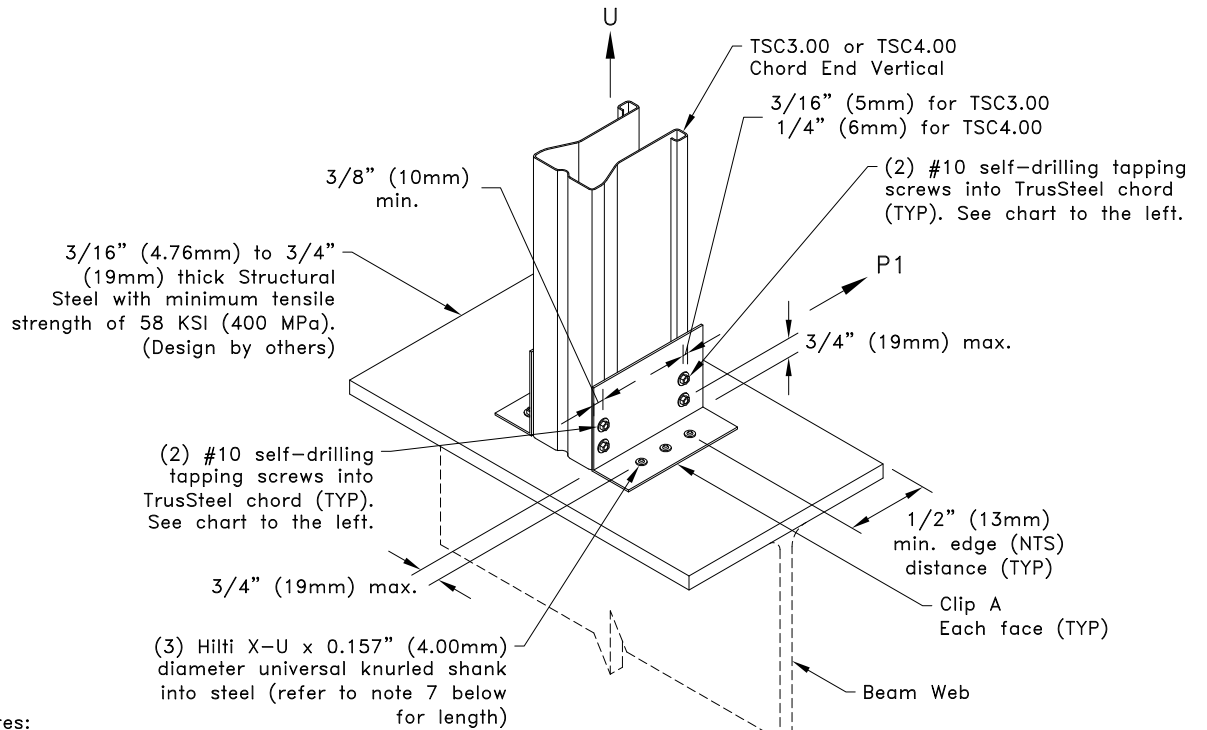

General Notes:

- Attachment of second clip on opposite face of chord is identical to what is detailed.
- This detail is for 1-Ply or 2-Ply truss only, for 3-Ply trusses contact a TrusSteel engineer.
- #10SDS Screw end distance and edge distance is 9/32" (7.14mm) minimum. Screw spacing is 9/16" (14.3mm) minimum.
- Hilti pin end distance and edge distance is 1/2" (12.7mm) minimum. Pin spacing is 1" (25.4mm) minimum.
- Pins must be driven perpendicular to steel surface.
- Care must be taken to ensure pins are not overdriven. Pins that are overdriven may puncture surface of clip causing damage. If clip is damaged, the values given on this detail are no longer valid.
- Pin length must be long enough to ensure the tip either penetrates completely through the steel, or shows evidence of the steel deformation that occurs just before penetration. For steel thicker than 1/2", pin length shall be long enough to ensure pin penetration of a minimum of 1/2".
- Do not install pins into area of beam flange directly above beam web.
- Allowable Hilti X-U Fastener values into steel bearing are per ICC ESR-2269 (February 2021). Refer to ESR regarding proper installation of fastener.
- Cold-Formed Steel calculations are per the 2020 supplement to AISI 1616 "North American Specification for the Design of Cold-Formed Steel Structural Members" (S100-16/S2-20).

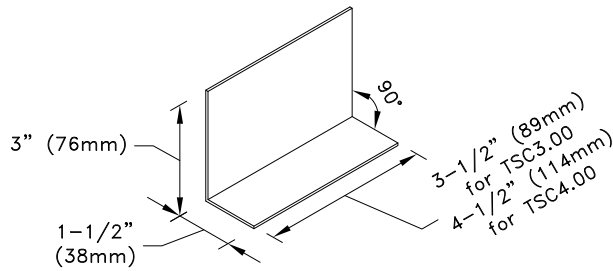

Clip A
16g ASTM A653 SS Grade 33 Class 1 G60
Bare metal thickness: (t) = 0.0538" (1.37mm)



www.TrusSteel.com

155 Harlem Ave., North Building, 4th Floor / Glenview, IL 60025 / (800) 755-6001

TSC3.00 or TSC4.00 Chord End Vertical Uplift Attachment To Structural Steel Bearing Using Hilti Pins (Steel From 3/16" to 3/4" Thick)

Alpine, a division of ITW Building Components Group, Inc. shall not be responsible for any performance failure in a connection due to a deviation from this detail. Any variation from this detail shall be approved in advance by Alpine, a division of ITW Building Components Group, Inc.

Standard Detail:
TS076A

Date:
06/01/22

TrusSteel Detail Category:
Truss-To-Bearing: Structural Steel