

Allowable Loads lbs (kN)^{A,C}

Chord	Clip on one face ^B					
	#10SDS into bottom chord			#12SDS into bottom chord		
	U	P1	P2	U	P1	P2
28TSC2.75	400 ^D (1.78)	620 (2.76)	310 (1.38)	400 ^D (1.78)	660 (2.94)	340 (1.51)
33TSC2.75	400 ^E (1.78)	770 (3.43)	340 (1.51)	400 ^E (1.78)	820 (3.65)	
43TSC2.75		1140 (5.07)			1220 (5.43)	
28TSC3.00 or 28TSC4.00	620 (2.76)		310 (1.38)	660 (2.94)		
33TSC3.00 or 33TSC4.00	680 (3.02)	770 (3.43)	340 (1.51)	680 (3.02)	820 (3.65)	
43TSC3.00 or 43TSC4.00		1140 (5.07)			1220 (5.43)	
54TSC3.00 or 54, 68 & 97TSC4.00		1250 (5.56)			1250 (5.56)	
Chord	Clip on both faces					
	#10SDS into bottom chord			#12SDS into bottom chord		
	U	P1	P2	U	P1	P2
28TSC	1230 (5.47)		630 (2.80)	1310 (5.83)		710 (3.16)
33TSC	1530 (6.81)		730 (3.25)	1630 (7.25)	1630 (7.25)	830 (3.69)
43TSC	1630 (7.25)	2280 (10.14)	880 (3.91)		2430 (10.81)	880 (3.91)
54, 68 & 97TSC		2500 (11.12)		2500 (11.12)		

A. Allowable loads shown are not in combination.
 B. Uplift connections with clip on one face require a web above connection. For values in chart, TSC2.75 minimum web is 33W.75x.75 and any web size is acceptable for TSC3.00 or TSC4.00.
 C. Chart values apply to steel thickness between 3/16" (4.76mm) and 1/2" (12.70mm), when connecting to steel greater than 1/2" (12.70mm) thick refer to TS039A.
 D. If web above connection is 33W.75x1.5, U = 620 lbs (2.76 kN).
 E. If web above connection is 33W.75x1.5, U = 680 lbs (3.02 kN).

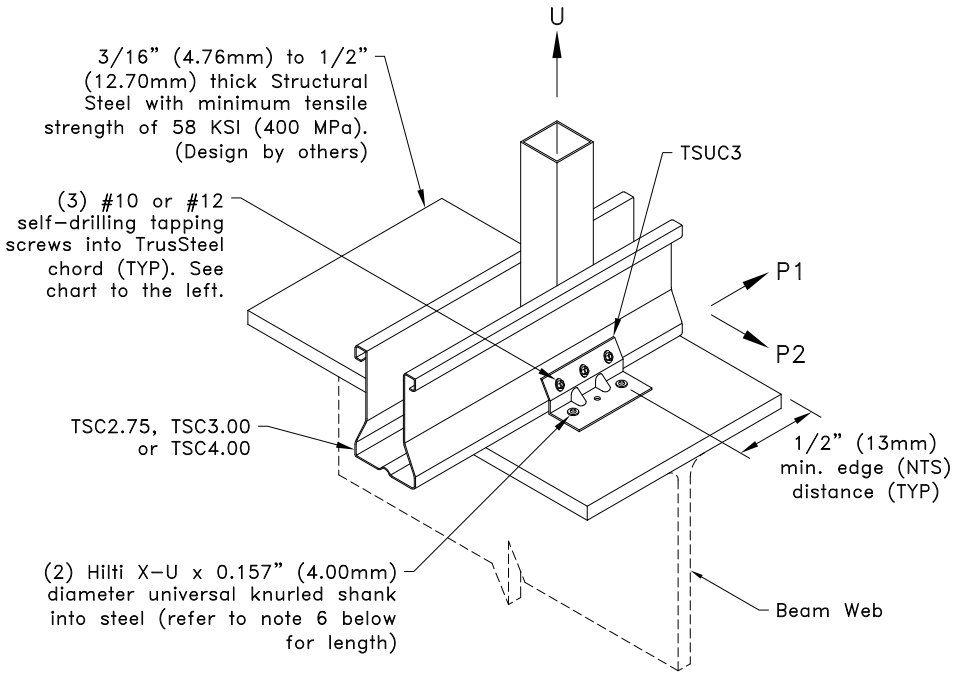
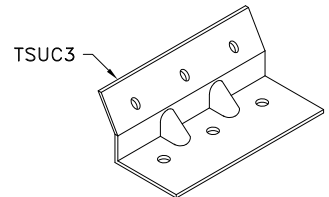

General Notes:

1. If a clip is required on both faces, attach the second clip to the opposite face of the chord as detailed.
2. Multi-ply trusses require a clip on each face. Refer to TrusSteel detail drawing TS023A for ply-to-ply connections for 3-Ply trusses with a clip on each face.
3. Install pins in the two outside holes of TSUC3 clip.
4. Pins must be driven through existing holes in TSUC3 clip and be driven perpendicular to steel surface.
5. Care must be taken to ensure pins are not overdriven. Pins that are overdriven may puncture surface of TSUC3 clip causing damage. If TSUC3 clip is damaged, the values given on this detail are no longer valid.
6. Pin length must be long enough to ensure the tip either penetrates completely through the steel, or shows evidence of the steel deformation that occurs just before penetration.
7. Do not install pins into area of beam flange directly above beam web.
8. Allowable Hilti X-U Fastener values into steel bearing are per ICC ESR-2269 (February 2021). Refer to ESR regarding proper installation of fastener.
9. Cold-Formed Steel calculations are per the 2020 supplement to AISI 2016 "North American Specification for the Design of Cold-Formed Steel Structural Members" (S100-16/S2-20).



TSUC3 Uplift Attachment To Structural Steel Bearing Using Hilti Pins (Steel From 3/16" to 1/2" Thick)

Alpine, a division of ITW Building Components Group, Inc. shall not be responsible for any performance failure in a connection due to a deviation from this detail. Any variation from this detail shall be approved in advance by Alpine, a division of ITW Building Components Group, Inc.

Standard Detail:
 TS039
 Date:
 06/01/22

TrusSteel Detail Category:
 Truss-To-Bearing: Structural Steel