

Allowable Loads lbs (kN) ^A					
Chord	Allowable Loads ^A	Clip on one face ^B		Clip on both faces	
		TS6WTC3	TS1WTC3	TS6WTC3	TS1WTC3
28TSC2.75	U	550 (2.45) ^C		1880 (8.36)	
	P1	940 (418)		1880 (8.36)	
33TSC2.75	U	550 (2.45) ^C		2340 (10.41)	
	P1	1170 (5.20)		2340 (10.41)	
43TSC2.75	U	550 (2.45) ^C		3170 (14.10)	3490 (15.52)
	P1	1640 (7.30)	1740 (7.74)	3290 (14.63)	3490 (15.52)
28TSC3.00 or 28TSC4.00	U	910 (4.05)		1880 (8.36)	
	P1	940 (4.18)		1880 (8.36)	
33TSC3.00 or 33TSC4.00	U	910 (4.05)		2340 (10.41)	
	P1	1170 (5.20)		2340 (10.41)	
43TSC3.00 or 43TSC4.00	U	910 (4.05) ^{D,E,F}	910 (4.05) ^{D,E,G}	3170 (14.10)	3490 (15.52)
	P1	1640 (7.30)	1740 (7.74)	3290 (14.63)	3490 (15.52)
54TSC3.00 or 54TSC4.00	U	910 (4.05) ^{D,E,F}	910 (4.05) ^{D,E,G}	3170 (14.10)	4900 (21.80)
	P1	1640 (7.30)	2380 (10.59)	3290 (14.63)	4750 (21.13)
68TSC4.00 or 97TSC4.00	U	910 (4.05) ^{D,E,F}	910 (4.05) ^{D,E,G}	3170 (14.10)	6260 (27.85)
	P1	1640 (7.30)	2380 (10.59)	3290 (14.63)	4750 (21.13)

- A. Allowable loads shown on this detail are not in combination.
 B. Uplift connections with clip on one face require a web above connection. For values in chart, TSC2.75 minimum web is 33W.75x.75 and TSC3.00 or TSC4.00 minimum web is 33W1.5x.75.
 C. If web above connection is 33W.75x1.5, U = 940 lbs (4.18 kN).
 D. If web above connection is 33C1.5x1.5, U = 1230 lbs (5.47 kN).
 E. If web above connection is 33W1.5x1.5 or 33Z1.5x1.62, U = 1400 lbs (6.23 kN).
 F. If web above connection is 33Z1.5x2.50, U = 1580 lbs (7.03 kN).
 G. If web above connection is 33Z1.5x2.50, U = 1740 lbs (7.74 kN).

Allowable Loads with Full Length Weld lbs (kN) ^A			
Chord	Allowable Loads ^A	Clip on both faces	
		TS6WTC3	TS1WTC3
54TSC3.00 or 54TSC4.00	U	3170 (14.10)	4900 (21.80)
	P1	3760 (16.73)	4900 (21.80)
68TSC4.00 or 97TSC4.00	U	3170 (14.10)	6910 (30.74)
	P1	3760 (16.73)	5430 (24.15)

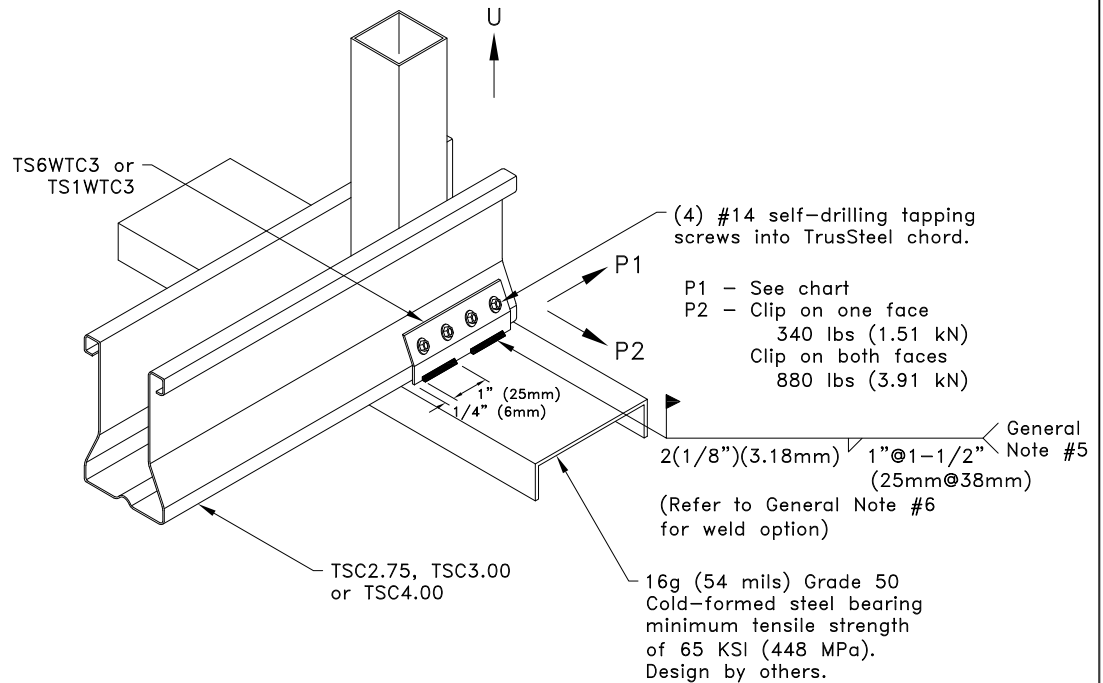
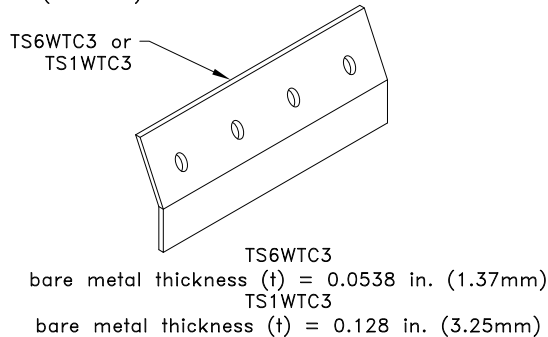

General Notes:

- The wall top plate is to be designed by the job engineer. The wall top plate and connection of top plate to wall stud must be designed to support the loads applied to it (downward, upward and lateral).
- If a clip is required on both faces, attach the second clip to the opposite face of the chord as detailed.
- Multi-ply trusses require a clip on each face. Refer to TrusSteel detail drawing TS023A for ply-to-ply connections for 3-Ply trusses with a clip on each face.
- Refer to TrusSteel Technical Bulletin 98.10.05 titled "Repair of Galvanized Surfaces" to restore corrosion resistant properties of the connection after welding.
- Weld values are based on a filler material with a minimum tensile strength of 70 ksi (483 MPa).
- In lieu of welds specified above, the full length of the TS6WTC3 / TS1WTC3 may be welded to the bearing.
- Cold-Formed Steel calculations are per the 2020 supplement to AISI 2016 "North American Specification for the Design of Cold-Formed Steel Structural Members" (S100-16/S2-20).



www.TrusSteel.com

155 Harlem Ave., North Building, 4th Floor / Glenview, IL 60025 / (800) 755-6001

**TS6WTC3 or TS1WTC3
Welded Truss Clip to
Cold-Formed Steel Bearing**

Alpine, a division of ITW Building Components Group, Inc. shall not be responsible for any performance failure in a connection due to a deviation from this detail. Any variation from this detail shall be approved in advance by Alpine, a division of ITW Building Components Group, Inc.

Standard Detail:

TS027F

Date:

06/01/22

TrusSteel Detail Category:

Truss-To-Bearing: Cold-Formed Steel