

Wind Criteria:
 ASCE 7-05, ASCE 7-10 or ASCE 7-16
 Enclosed building
 30' (9144mm) mean height
 CAT III & IV, EXP C
 No speed-up increase factor taken for topographic effects; $K_{zt} = 1.0$

Max Loading:
 Top chord live load = 40 psf (1.92 kN/m²)
 Top chord dead load = 10 psf (0.48 kN/m²)
 Wind dead load = 5 psf (0.24 kN/m²)
 Soffit load on overhang off of gable face = 10 psf (0.48 kN/m²)
 Max weight on face of gable = 10 psf (0.48 kN/m²)

600S162-33 Stud Maximum Lengths				
Windspeed:	ASCE 7-05 - 110 MPH (49 m/s)	ASCE 7-05 - 150 MPH (67 m/s)	ASCE 7-05 - 150 MPH (67 m/s)	ASCE 7-05 - 150 MPH (67 m/s)
	ASCE 7-10 - 140 MPH (62 m/s)	ASCE 7-10 - 190 MPH (85 m/s)	ASCE 7-10 - 190 MPH (85 m/s)	ASCE 7-10 - 190 MPH (85 m/s)
	ASCE 7-16 - 140 MPH (62 m/s)	ASCE 7-16 - 190 MPH (85 m/s)	ASCE 7-16 - 190 MPH (85 m/s)	ASCE 7-16 - 190 MPH (85 m/s)
Gable Stud Spacing:	16" (407mm) O.C.	24" (610mm) O.C.	16" (407mm) O.C.	24" (610mm) O.C.
Unbraced Single Stud	7'9" (2362mm)	5'6" (1676mm)	4'3" (1295mm)	2'9" (838mm)
Diagonally Braced Single Stud	15'9" (4801mm)	14'0" (4267mm)	12'0" (3658mm)	8'0" (2438mm)
Unbraced Double Stud	9'9" (2972mm)	8'9" (2667mm)	8'3" (2515mm)	6'0" (1829mm)

Deflection Criteria Note: Unbraced Single Stud values meet L/870 max.
 Diagonally Braced Single Stud values meet L/4200 max
 Unbraced Double Stud values meet L/780 max.

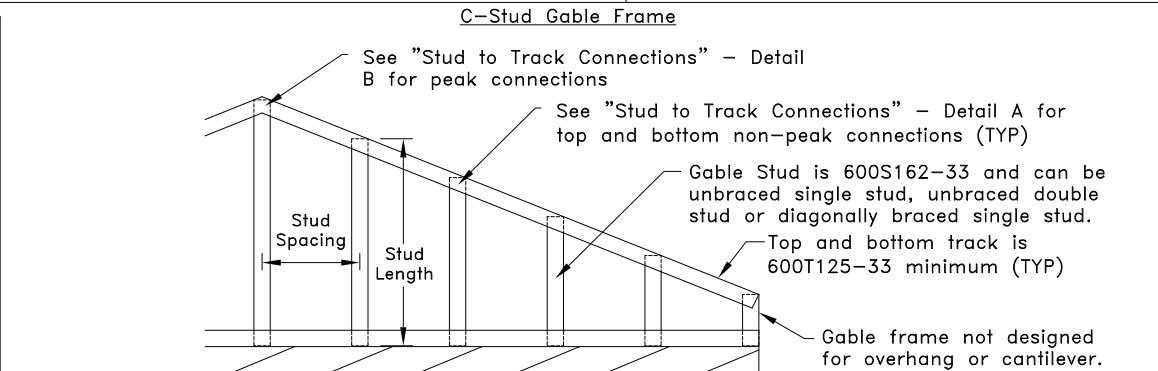
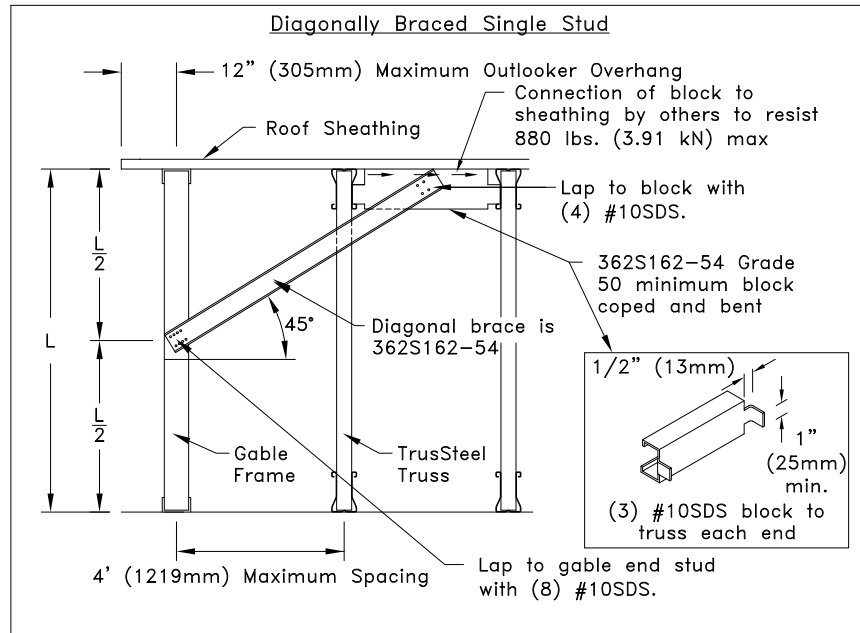
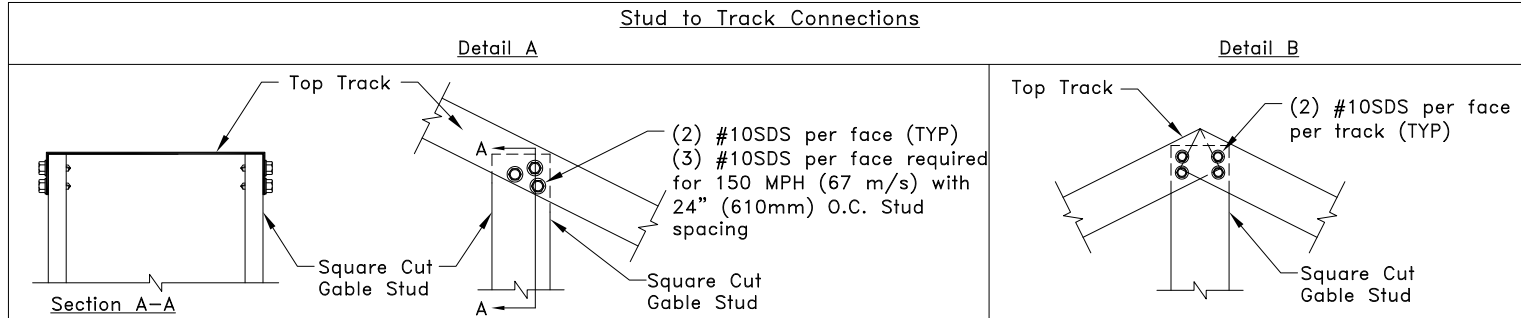
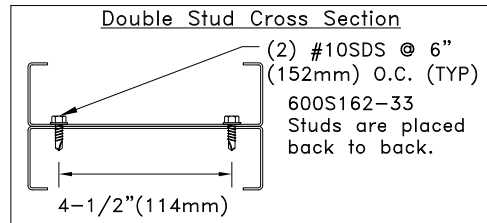

- General Notes:**
1. SDS = Self-Drilling Tapping Screw
 2. Screw spacing is 9/16" (14.3mm) minimum.
 3. Screw edge distance is 1/4" (6.4mm) and end distance is 3/8" (9.5mm) minimum.
 4. The gable end frame is assumed to be supported vertically, horizontally and laterally along its entire length. The building designer is responsible for the design of the support wall, the ceiling and roof diaphragm, connection of the gable frame to these supports, and transfer of in-plane shear loads.
 5. Intended for use with TrusSteel roof truss systems only.
 6. Gable stud web is perpendicular to the length of the track.
 7. Cold-Formed Steel Calculations are per the AISI 2016 "North American Specification for the Design of Cold-Formed Steel Structural Members" (S100-16) and AISI 2015 "North American Standard for Cold-Formed Steel Structural Framing" (S240-15).



6" C-Stud Gable Framing

Alpine, a division of ITW Building Components Group, Inc. shall not be responsible for any performance failure in a connection due to a deviation from this detail. Any variation from this detail shall be approved in advance by Alpine, a division of ITW Building Components Group, Inc.

Standard Detail:
 TS014

Date:
 10/11/18

TrusSteel Detail Category:
 Gable Framing

Florida: 6750 Forum Drive, Suite 305 / Orlando, FL 32821 / (800) 755-6001
 Missouri: 13723 Riverport Drive, Suite 200 / Maryland Heights, MO 63043 / (800) 326-4102