

TSC2.75 or TSC4.00

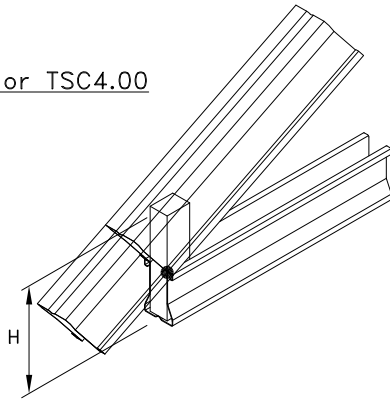

CANT2.75 or CANT4.00

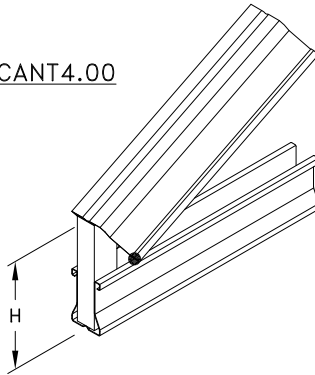

SWAGE2.75 or SWAGE4.00

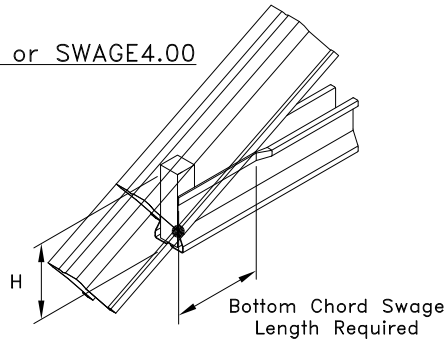

MIN2.75 or MIN4.00

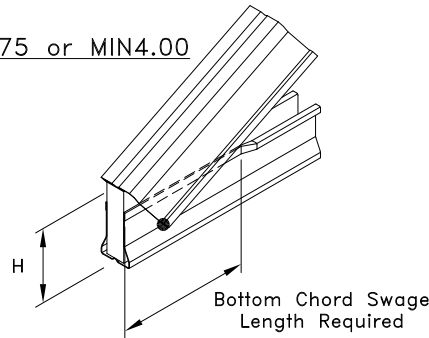

Heel Height "H" for TSC2.75

Pitch	TSC2.75	CANT2.75	SWAGE2.75	MIN2.75
2/12 (9.46°)	5-9/16" (141mm)	5-7/16" (138mm)	4-5/16" (110mm)	4-3/16" (106mm)
3/12 (14.04°)	5-9/16" (141mm)	5-7/16" (138mm)	4-5/16" (110mm)	4-3/16" (106mm)
4/12 (18.43°)	5-5/8" (143mm)	5-3/8" (137mm)	4-3/8" (111mm)	4-1/8" (105mm)
5/12 (22.62°)	5-3/4" (146mm)	5-5/16" (135mm)	4-1/2" (114mm)	4-1/16" (103mm)
6/12 (26.56°)	5-13/16" (148mm)	5-3/16" (132mm)	4-9/16" (116mm)	3-15/16" (100mm)
7/12 (30.26°)	5-15/16" (151mm)	5-1/8" (130mm)	4-11/16" (119mm)	3-7/8" (98mm)
8/12 (33.69°)	6-1/16" (154mm)	5-1/16" (129mm)	4-13/16" (122mm)	3-13/16" (97mm)
9/12 (36.87°)	6-3/16" (157mm)	4-15/16" (125mm)	4-15/16" (125mm)	3-11/16" (94mm)
10/12 (39.81°)	6-5/16" (160mm)	4-7/8" (124mm)	5-1/16" (129mm)	3-5/8" (92mm)
11/12 (42.51°)	6-1/2" (165mm)	4-3/4" (121mm)	5-1/4" (133mm)	3-1/2" (89mm)
12/12 (45°)	6-5/8" (168mm)	4-11/16" (119mm)	5-3/8" (137mm)	3-7/16" (87mm)

Heel Height "H" for TSC3.00 or TSC4.00

Pitch	TSC4.00	CANT4.00	SWAGE4.00	MIN4.00
2/12 (9.46°)	8-1/16" (205mm)	7-15/16" (202mm)	6-3/4" (171mm) ^A	6-3/4" (171mm) ^A
3/12 (14.04°)	8-1/8" (206mm)	7-7/8" (200mm)	6-1/8" (156mm) ^A	6-1/8" (156mm) ^A
4/12 (18.43°)	8-3/16" (208mm)	7-13/16" (198mm)	5-11/16" (144mm)	5-9/16" (141mm) ^A
5/12 (22.62°)	8-5/16" (211mm)	7-11/16" (195mm)	5-13/16" (148mm)	5-3/16" (132mm)
6/12 (26.56°)	8-1/2" (216mm)	7-9/16" (192mm)	6" (152mm)	5-1/16" (129mm)
7/12 (30.26°)	8-5/8" (219mm)	7-7/16" (189mm)	6-1/8" (156mm)	4-15/16" (125mm)
8/12 (33.69°)	8-13/16" (224mm)	7-5/16" (186mm)	6-5/16" (160mm)	4-13/16" (122mm)
9/12 (36.87°)	9" (229mm)	7-3/16" (183mm)	6-1/2" (165mm)	4-11/16" (119mm)
10/12 (39.81°)	9-3/16" (233mm)	7-1/16" (179mm)	6-11/16" (170mm)	4-9/16" (116mm)
11/12 (42.51°)	9-7/16" (240mm)	6-15/16" (176mm)	6-15/16" (176mm)	4-7/16" (113mm)
12/12 (45°)	9-11/16" (246mm)	6-13/16" (173mm)	7-3/16" (183mm)	4-5/16" (110mm)

A. Heel heights that are affected by the 8" (203mm) maximum swage length.

General Notes:

1. Heel names given are as they appear in TrusSteel View.
2. ● = Intersection of the truss top chord and bottom chord.
3. Bottom chord swage length not to exceed 8" (203mm).



www.TrusSteel.com

Florida: 6750 Forum Drive, Suite 305 / Orlando, FL 32821 / (800) 755-6001
 Missouri: 13723 Riverport Drive, Suite 200 / Maryland Heights, MO 63043 / (800) 326-4102

TSC2.75, TSC3.00 And
 TSC4.00 Standard Heel
 Height Detail

Alpine, a division of ITW Building Components Group, Inc. shall not be responsible for any performance failure in a connection due to a deviation from this detail. Any variation from this detail shall be approved in advance by Alpine, a division of ITW Building Components Group, Inc.

Standard Detail:

TS006

Date:

10/11/18

TrusSteel Detail Category:

Heels