

3D View of TSCC664 Clip Conn.

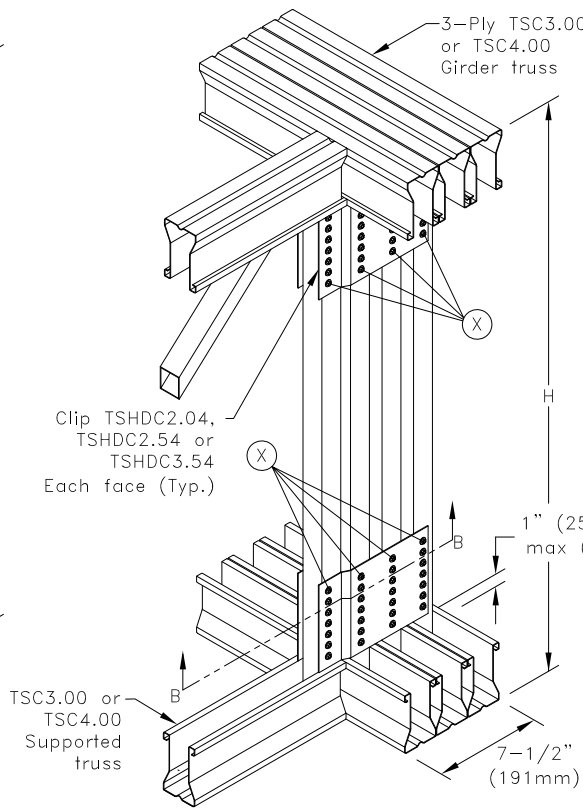

3D View of TSHDC Clip Conn.

Allowable Reaction and Uplift lbs (kN)	
X ^A	H = 24 in. (610mm) minimum
	R = U lbs (kN)
5	3000 (13.34)
6	4000 (17.79)
7	4700 (20.91)

A. The quantity "X" refers to the number of #10SDS (Self-Drilling Tapping Screws) that are required on each side of each clip into the web member.

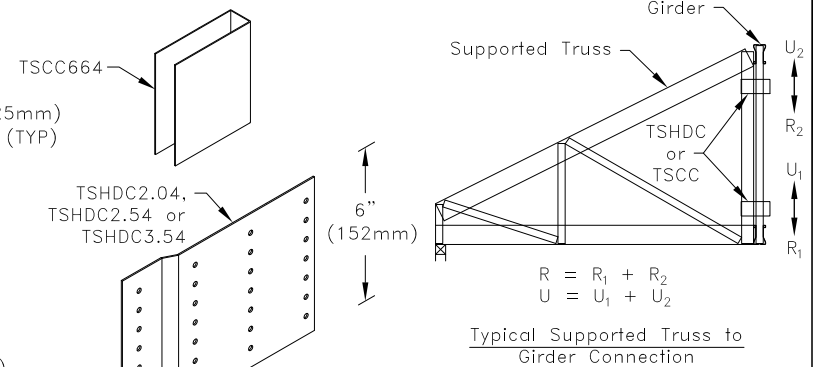

Typical Supported Truss to Girder Connection

General Notes:

- The top and bottom chords of all trusses shall be properly connected to structural sheathing or purlins, designed by others.
- Screw spacing, edge distance and end distance is 9/16" (14mm) minimum.
- The supported truss must be designed utilizing a clip bearing type.
- R = Allowable Reaction and U = Allowable Uplift, at each clip location.
- Cold-Formed Steel Calculations are per the 2010 supplement to the AISI 2007 "North American Specifications for the Design of Cold-Formed Steel Structural Members" (S100-07/S2-10).
- If supported truss web is a Z-web, refer to TS060C for connection.

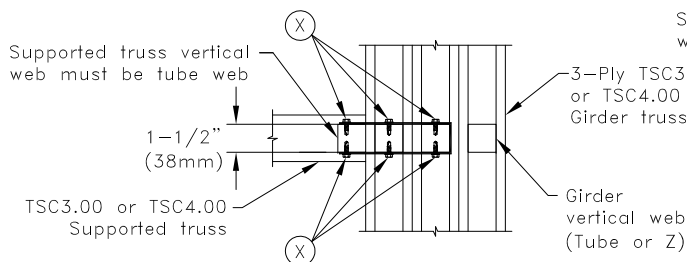

Section A-A
If width of girder vertical web is:
1-1/2" (38mm) use clip TSCC664

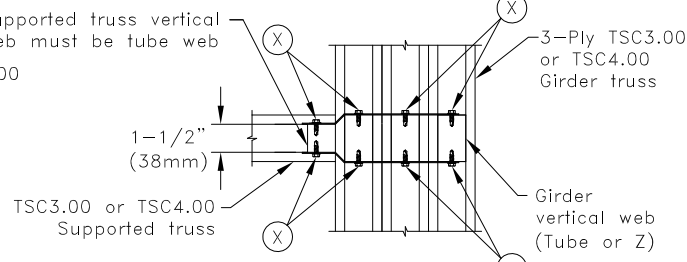

Section B-B
If width of girder vertical web is:
2" (51mm) use clip TSHDC2.04
2-1/2" (64mm) use clip TSHDC2.54
3-1/2" (90mm) use clip TSHDC3.54



Heavy TSC3.00 or TSC4.00 Truss-To-Truss Connection (3 Ply Girder) Tube Webs

ITW Building Components Group, Inc. shall not be responsible for any performance failure in a connection due to a deviation from this detail. Any variation from this detail shall be approved in advance by ITW Building Components Group, Inc.

Standard Detail:
TS060B
Date:
07/16/12

TrusSteel Detail Category:
Truss-To-Truss Connections

Florida: 1950 Marley Drive / Haines City, FL 33844 / (800) 755-6001
Missouri: 13389 Lakefront Drive / Earth City, MO 63045 / (800) 326-4102