

General Notes:

1. Circled numbers refer to required number of #10SDS per connected face.
2. Screw spacing, edge distance and end distance for #10SDS is 9/16" (14mm) minimum.
3. Refer to approved bracing design for required bracing material, connections and allowable downward load.
4. Piggyback truss shall be seated directly on top of purlins.
5. Refer to approved truss drawings for piggyback truss designs. Length of bottom chord panels in piggyback trusses shall not exceed 4'-0" (1219mm).
6. Plates shown in Details A2 and B2 shall be made from 20g ASTM A653 SS Grade 33 G60, with a minimum bare metal thickness of 0.0329" (0.84mm).
7. Cold-Formed Steel Calculations are per the 2010 supplement to the AISI 2007 "North American Specifications for the Design of Cold-Formed Steel Structural Members" (S100-07/S2-10).
8. Wind Calculations are per ASCE 7-05 or ASCE 7-10 assuming the following:
 - Cat III & IV
 - EXP C
 - 30 ft (9144mm) mean roof height
 - Closed building
 - 5 psf (0.24 kN/m²) wind dead load
 - 12/12 pitch maximum
 - 60 psf (2.87 kN/m²) Top Chord load
 - No speed up factor taken for topographic effect: K_{zt} = 1.0

NOTICE Wind speeds given below assume that connections do NOT resist any lateral load and trusses are over continuous bearing. Contact a TrusSteel engineer for assistance.

| Windspeed - MPH (m/s) for Details A1 & A2 | | | | |
|---|------------------|--------------------|------------------|--------------------|
| ⊗ | ASCE 7-05 | | ASCE 7-10 | |
| | Clip On One Face | Clip On Both Faces | Clip On One Face | Clip On Both Faces |
| 2 | 130 (58) | 160 (72) | 160 (72) | 200 (89) |
| 3 | 160 (72) | -- | 200 (89) | -- |

| Windspeed - MPH (m/s) for Details B1 & B2 | | |
|---|------------------|------------------|
| ⊗ | ASCE 7-05 | ASCE 7-10 |
| | Clip On One Face | Clip On One Face |
| 2 | 130 (58) | 160 (72) |
| 3 | 160 (72) | 200 (89) |

| Windspeed - MPH (m/s) for Detail C | |
|------------------------------------|-----------|
| ASCE 7-05 | ASCE 7-10 |
| 160 (72) | 200 (89) |

Detail A1

Detail A2

Detail B1

Detail B2

Detail C

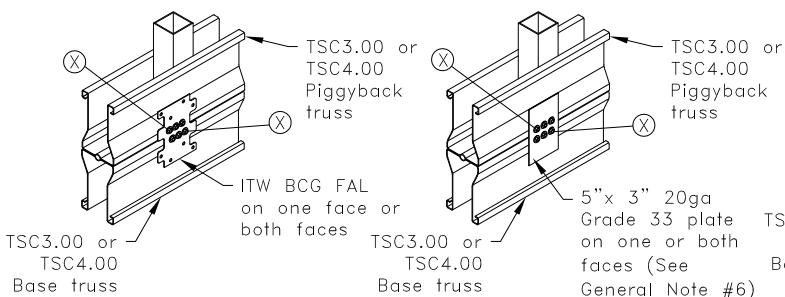

Piggyback and Base Truss Have Same Size Chord

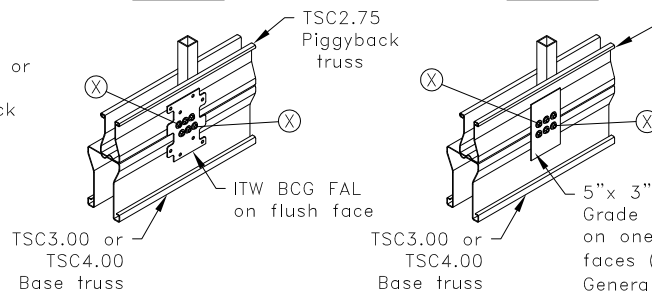

TSC2.75 Piggyback and TSC3.00 or TSC4.00 Base Truss (Chord faces flush with connector)

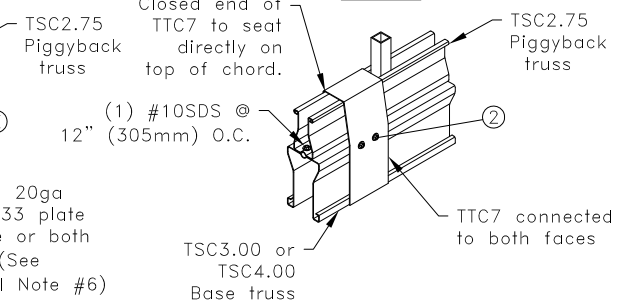

TSC2.75 Piggyback and TSC3.00 or TSC4.00 Base Truss (Piggyback centered over base truss)

TrusSteel[®]

www.TrusSteel.com

Piggyback Uplift Connection
(Piggyback Sits Directly On Base Truss)

ITW Building Components Group, Inc. shall not be responsible for any performance failure in a connection due to a deviation from this detail. Any variation from this detail shall be approved in advance by ITW Building Components Group, Inc.

Standard Detail:
TS003B

Date:
07/16/12

TrusSteel Detail Category:
Piggybacks

Florida: 1950 Marley Drive / Haines City, FL 33844 / (800) 755-6001
Missouri: 13389 Lakefront Drive / Earth City, MO 63045 / (800) 326-4102